

ADJ VIZI WASH Z19

User Manual

©2022 ADJ Products, LLC all rights reserved. Information, specifications, diagrams, images, and instructions herein are subject to change without notice. ADJ Products, LLC logo and identifying product names and numbers herein are trademarks of ADJ Products, LLC. Copyright protection claimed includes all forms and matters of copyrightable materials and information now allowed by statutory or judicial law or hereinafter granted. Product names used in this document may be trademarks or registered trademarks of their respective companies and are hereby acknowledged. All non-ADJ Products, LLC brands and product names are trademarks or registered trademarks of their respective companies.

ADJ Products, LLC and all affiliated companies hereby disclaim any and all liabilities for property, equipment, building, and electrical damages, injuries to any persons, and direct or indirect economic loss associated with the use or reliance of any information contained within this document, and/or as a result of the improper, unsafe, insufficient and negligent assembly, installation, rigging, and operation of this product.

ADJ PRODUCTS LLC World Headquarters

6122 S. Eastern Ave. | Los Angeles, CA 90040 USA

Tel: 800-322-6337 | Fax: 323-582-2941 | www.adj.com | lsupport@adj.com

ADJ Supply Europe B.V.

Junostraat 2 | 6468 EW Kerkrade | Netherlands

Tel: +31 45 546 85 00 | Fax: +31 45 546 85 99 | www.americandj.eu | service@americandj.eu

Europe Energy Saving Notice

Energy Saving Matters (EuP 2009/125/EC)

Saving electric energy is a key to help protecting the environment. Please turn off all electrical products when they are not in use. To avoid power consumption in idle mode, disconnect all electrical equipment from power when not in use. Thank you!

DOCUMENT VERSION



Due to additional product features and/or enhancements, an updated version of this document may be available online.

Please check www.adj.com for the latest revision/update of this manual before beginning installation and/or programming.

Date	Document Version	Software Version	DMX Channels	Notes
07/23/19	1.0	1.2	12/16/28/44	Initial Release
01/15/20	1.2	1.6	13/14/17/29/45	DMX Channel Modes Updated
06/28/21	1.4	N/C	No Change	Updated Dimensional Drawings
07/02/21	1.6	N/C	No Change	Updated Safety Guidelines, Installation, & Overview
05/10/22	1.8	3.0	13/14/17/18/29/30/45/46	Updated DMX Traits & System Menu

CONTENTS

General Information	4
Limited Warranty (USA Only)	5
Safety Guidelines	6
Maintenance Guidelines	9
Fixture Overview	10
Color Macro Chart	11
Installation Guidelines	12
DMX Set Up	15
DMX Addressing	16
System Menu	17
Pixel Zone Layout	25
Target Modes	26
Dimmer Mode Graphs	27
DMX Traits: Channel Functions & Values	28
Error Codes	31
Specifications	32
Optional Accessories	34

GENERAL INFORMATION

INTRODUCTION

Please read and understand the instructions in this manual carefully and thoroughly before attempting to operate this device. These instructions contain important safety and use information.

This product is intended for use by professionally trained personnel only, and is not suitable for private use.

Unpacking

Every device has been thoroughly tested and has been shipped in perfect operating condition. Carefully check the shipping carton for damage that may have occurred during shipping. If the carton is damaged, carefully inspect the device for damage, and be sure all accessories necessary to install and operate the device have arrived intact. In the event damage has been found or parts are missing, please contact our customer support team for further instructions. Please do not return this device to your dealer without first contacting customer support. Please do not discard the shipping carton in the trash. Please recycle whenever possible.

BOX CONTENTS

Omega Brackets
1.83M locking power cable

CUSTOMER SUPPORT

Contact ADJ Service for any product related service and support needs. Also visit forums.adj.com with questions, comments or suggestions.

ADJ SERVICE USA - Monday - Friday 8:00am to 4:30pm PST
323-582-2650 | Fax: 323-832-2941 | support@adj.com

ADJ SERVICE EUROPE - Monday - Friday 08:30 to 17:00 CET
+31 45 546 85 60 | Fax: +31 45 546 85 96 | support@adj.eu

REPLACEMENT PARTS please visit parts.adj.com



IMPORTANT NOTICE!

THERE ARE NO USER SERVICEABLE PARTS INSIDE THIS UNIT. DO NOT ATTEMPT ANY REPAIRS YOURSELF; DOING SO WILL VOID YOUR MANUFACTURER'S WARRANTY. DAMAGES RESULTING FROM MODIFICATIONS TO THIS FIXTURE AND/OR THE DISREGARD OF SAFETY INSTRUCTIONS AND GUIDELINES IN THIS MANUAL VOID THE MANUFACTURER'S WARRANTY AND ARE NOT SUBJECT TO WARRANTY CLAIMS AND/OR REPAIRS.

LIMITED WARRANTY (USA ONLY)

- A. ADJ Products, LLC hereby warrants, to the original purchaser, ADJ Products, LLC products to be free of manufacturing defects in material and workmanship for a prescribed period from the date of purchase (see specific warranty period on reverse). This warranty shall be valid only if the product is purchased within the United States of America, including possessions and territories. It is the owner's responsibility to establish the date and place of purchase by acceptable evidence, at the time service is sought.
- B. For warranty service, you must obtain a Return Authorization number (RA#) before sending back the product-please contact ADJ Products, LLC Service Department at 800-322-6337. Send the product only to the ADJ Products, LLC factory. All shipping charges must be pre-paid. If the requested repairs or service (including parts replacement) are within the terms of this warranty, ADJ Products, LLC will pay return shipping charges only to a designated point within the United States. If the entire instrument is sent, it must be shipped in its original package. No accessories should be shipped with the product. If any accessories are shipped with the product, ADJ Products, LLC shall have no liability whatsoever for loss of or damage to any such accessories, or for the safe return thereof.
- C. This warranty is void if the serial number has been altered or removed; if the product is modified in any manner which ADJ Products, LLC concludes, after inspection, affects the reliability of the product, if the product has been repaired or service by anyone other than ADJ Products, LLC factory unless prior written authorization was issued to purchaser by ADJ Products, LLC; if the product is damaged because not properly maintained as set forth in the instruction manual.
- D. This is not a service contract, and this warranty does not include maintenance, cleaning or periodic check up. During the period specified above, ADJ Products, LLC will replace defective parts at its expense with new or refurbished parts, and will absorb all expenses for warranty service and repair labor by reason of defects in material or workmanship. The sole responsibility of ADJ Products, LLC under this warranty shall be limited to the repair of the product, or replacement thereof, including parts, at the sole discretion of ADJ Products, LLC. All products covered by this warranty were manufactured after August 15, 2012, and bear identifying marks to that effect.
- E. ADJ Products, LLC reserves the right to make changes in design and/or improvements upon its products without any obligation to include these changes in any products theretofore manufactured.
- F. No warranty, whether expressed or implied, is given or made with respect to any accessory supplied with products described above. Except to the extent prohibited by applicable law, all implied warranties made by ADJ Products, LLC in connection with this product, including warranties of merchantability or fitness, are limited in duration to the warranty period set forth above. And no warranties, whether expressed or implied, including warranties of merchantability or fitness, shall apply to this product after said period has expired. The consumer's and/or Dealer's sole remedy shall be such repair or replacement as is expressly provided above; and under no circumstances shall ADJ Products, LLC be liable for any loss or damage, direct or consequential, arising out of the use of, or inability to use, this product.
- G. This warranty is the only written warranty applicable to ADJ Products, LLC Products and supersedes all prior warranties and written descriptions of warranty terms and conditions heretofore published.

LIMITED WARRANTY PERIODS

- **Non L.E.D. Lighting Products = 1-year (365 days) Limited Warranty** (Such as: Special Effect Lighting, Intelligent Lighting, UV lighting, Strobes, Fog Machines, Bubble Machines, Mirror Balls, Par Cans, Trussing, Lighting Stands etc. excluding LED and lamps)
- **Laser Products = 1 Year (365 Days) Limited Warranty** (excludes laser diodes which have 6 month limited warranty)
- **L.E.D. Products = 2-year (730 days) Limited Warranty** (excluding batteries which have a 180 day limited warranty)
Note: 2 Year Warranty only applies to purchases within the United States.
- **StarTec Series = 1 Year Limited Warranty** (excluding batteries which have a 180 day limited warranty)
- **ADJ DMX Controllers = 2 Year (730 Days) Limited Warranty**

SAFETY GUIDELINES

This device is a sophisticated piece of electronic equipment. To guarantee a smooth operation, it is important to follow all instructions and guidelines in this manual. ADJ PRODUCTS, LLC. is not responsible for injury and/or damages resulting from the misuse of this device due to the disregard of the information printed in this manual. Only the original included parts and/or accessories for this device should be used. Any modifications to the device, included and/or accessories will void the original manufactures warranty and increase the risk of damage and/or personal injury.



PROTECTION CLASS 1 - FIXTURE MUST BE PROPERLY GROUNDED



**THERE ARE NO USER SERVICEABLE PARTS INSIDE THIS UNIT.
DO NOT ATTEMPT ANY REPAIRS YOURSELF; DOING SO WILL VOID YOUR MANUFACTURER'S WARRANTY. DAMAGES RESULTING FROM MODIFICATIONS TO THIS FIXTURE AND/OR THE DISREGARD OF SAFETY INSTRUCTIONS AND GUIDELINES IN THIS MANUAL VOID THE MANUFACTURE'S WARRANTY AND ARE NOT SUBJECT TO ANY WARRANTY CLAIMS AND/OR REPAIRS.**



**DO NOT PLUG FIXTURE INTO A DIMMER PACK!
NEVER OPEN THIS FIXTURE WHILE IN USE!
UNPLUG POWER BEFORE SERVICING FIXTURE!
NEVER TOUCH FIXTURE DURING OPERATION, AS IT MAY BE HOT!
KEEP FLAMMABLE MATERIALS AWAY FROM FIXTURE!**

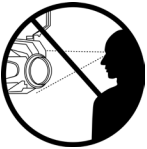

**NEVER LOOK DIRECTLY INTO THE LIGHT SOURCE!
RETINA INJURY RISK - MAY INDUCE BLINDNESS!
SENSITIVE PERSONS MAY SUFFER AN EPILEPTIC SHOCK!**



**INDOOR / DRY LOCATIONS USE ONLY!
DO NOT EXPOSE FIXTURE TO RAIN AND MOISTURE!**



**MINIMUM DISTANCE TO OBJECTS/SURFACES
MUST BE 6.6 FEET (2 METERS)
MAXIMUM TEMP OF EXTERNAL SURFACE 167°F (75°C)
MINIMUM DISTANCE OF INFLAMMABLE MATERIALS
FROM THE SURFACE 0.7 FEET (0.2 METER)**

SAFETY GUIDELINES

DO NOT TOUCH the fixture housing during operation. Turn OFF the power and allow approximately 15-minutes for the fixture to cool down before serving.

DO NOT shake fixture, avoid brute force when installing and/or operating fixture.

DO NOT operate fixture if the power cord is frayed, crimped, damaged and/or if any of the power cord connectors are damaged and do not insert into the fixture securely with ease. NEVER force a power cord connector into the fixture. If the power cord or any of its connectors are damaged, replace it immediately with a new one of similar power rating.

DO NOT block any air ventilation slots.

All fan and air inlets must remain clean and never blocked.

Allow approx. 7.9" (20cm) between fixture and other devices or a wall for proper cooling.

When installing fixture in a suspended environment, always use mounting hardware that is no less than M10 x 25 mm, and always install fixture with an appropriately rated safety cable.

Always disconnect fixture from main power source before performing any type of service and/or cleaning procedure. Only handle the power cord by the plug end, never pull out the plug by tugging the wire portion of the cord.

During the initial operation of this fixture, a light smoke or smell may emit from the interior of the fixture. This is a normal process and is caused by excess paint in the interior of the casing burning off from the heat associated with the lamp and will decrease gradually over time.

Consistent operational breaks will ensure fixture will function properly for many years.

ONLY Use original packaging and materials to transport the fixture in for service.

SAFETY GUIDELINES

POTENTIAL INTERNAL FIXTURE DAMAGE FROM EXTERNAL SOURCES OF LIGHT BEAMS

External sources of light beams from direct sunlight, lighting moving head fixtures, and lasers, which are focused directly towards the exterior housing and/or penetrate the front lens opening of ADJ lighting fixtures, can cause severe internal damage including burning to optics, dichroic color filters, glass and metal gobos, prisms, animation wheels, frost filters, iris, shutters, motors, belts, wiring, discharge lamps, and LEDs.

This issue is not specific to ADJ lighting fixtures, it is a common issue with lighting fixtures from all manufacturers. Although there is no true way to fully prevent this issue from happening, the following guidelines can prevent any potential damage from occurring if followed. Contact ADJ Service for more details.

DO NOT EXPOSE THE FIXTURE AND/OR FRONT LENS OPENING TO LIGHT BEAMS FROM DIRECT SUNLIGHT, OTHER LIGHTING MOVING HEAD FIXTURES, AND LASERS WHILE UNPACKING, INSTALLATION, USE, AND EXTENDED IDLE TIMES OUTDOORS. DO NOT FOCUS A LIGHT BEAM FROM ONE LIGHTING FIXTURE DIRECTLY TOWARDS ANOTHER.

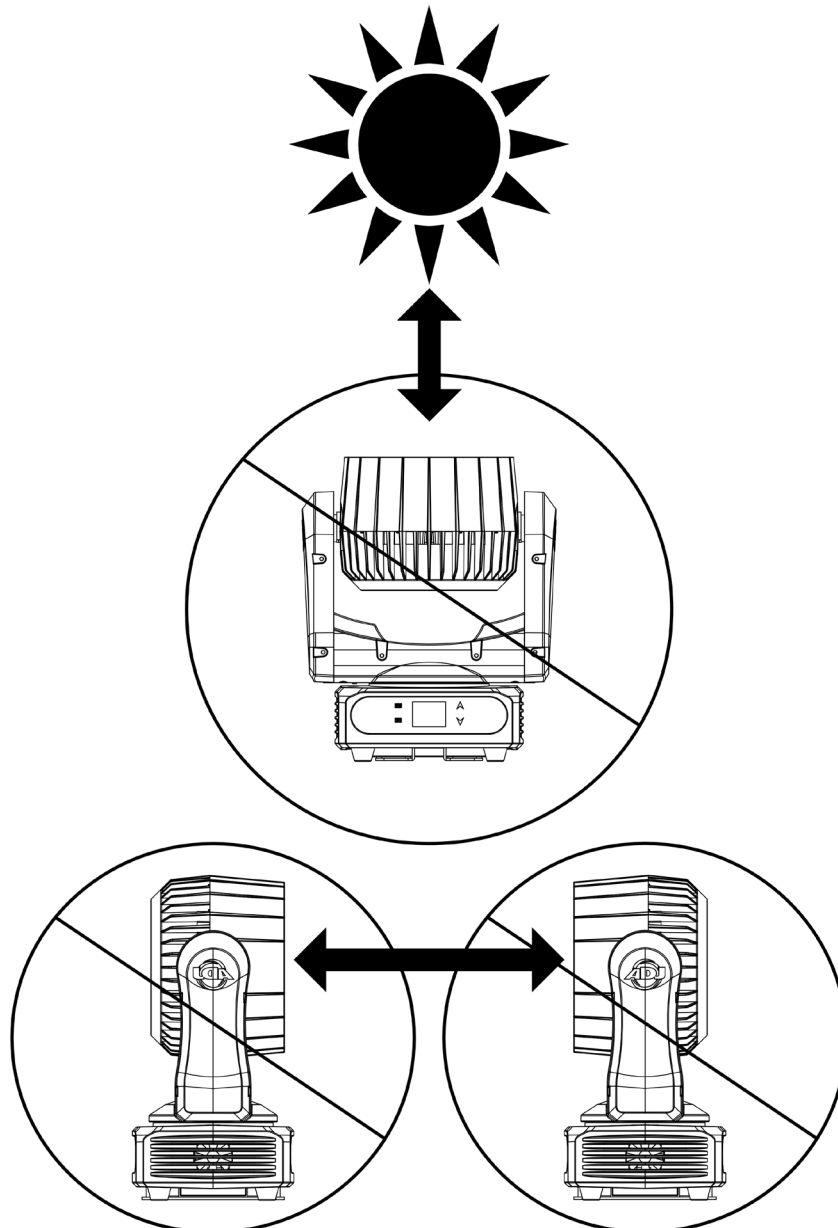

MAINTENANCE GUIDELINES



DISCONNECT POWER BEFORE PERFORMING ANY MAINTENANCE!

CLEANING

Frequent cleaning is recommended to ensure proper function, optimized light output, and an extended life. The frequency of cleaning depends on the environment in which the fixture operates: damp, smoky, or particularly dirty environments can cause greater accumulation of dirt on the fixture's optics. Clean the external lens surface periodically with a soft cloth to avoid dirt/debris accumulation.

NEVER use alcohol, solvents, or ammonia-based cleaners.

MAINTENANCE

Regular inspections are recommended to ensure proper function and extended life.

There are no user serviceable parts inside this fixture, please refer all other service issues to an authorized ADJ service technician. Should you need any spare parts, please order genuine parts from your local ADJ dealer.

Please refer to the following points during routine inspections:

- A detailed electrical check by an approved electrical engineer every three months, to make sure the circuit contacts are in good condition in order to prevent overheating.
- Be sure all screws and fasteners are securely tightened at all times. Loose screws may fall out during normal operation, resulting in damage or injury as larger parts could fall.
- Check for any deformations on the housing, color lenses, rigging hardware, and rigging points (ceiling, suspension, trussing). Deformations in the housing could allow for dust or liquids to enter into the fixture. Damaged rigging points or unsecured rigging could cause fixture to fall and seriously injure a person(s).
- Electric power supply cables must not show any damage, material fatigue, or sediments.
- **NEVER** remove the ground prong from the power cable.

FIXTURE DISASSEMBLY

The following points should be observed after performing any maintenance procedure that requires disassembly of the unit:

- After the unit has been reassembled, open the valve, and allow the light to run for approximately 2 hours to dry out any moisture that has been trapped inside the fixture. The process should continue until indicated humidity drops below 15% for the head and 30% for the base.
- Once this has been achieved, the light can be switched off, but the unit should remain connected to power so that the cooling fan can cool down the unit. Please note that allowing cool down time should **ALWAYS** be done after lamp operation.
- Some units may require partial disassembly in order to gain access to the valve. Please contact Elation service for information regarding the location and access procedure for the valve on your specific unit model.

FIXTURE OVERVIEW

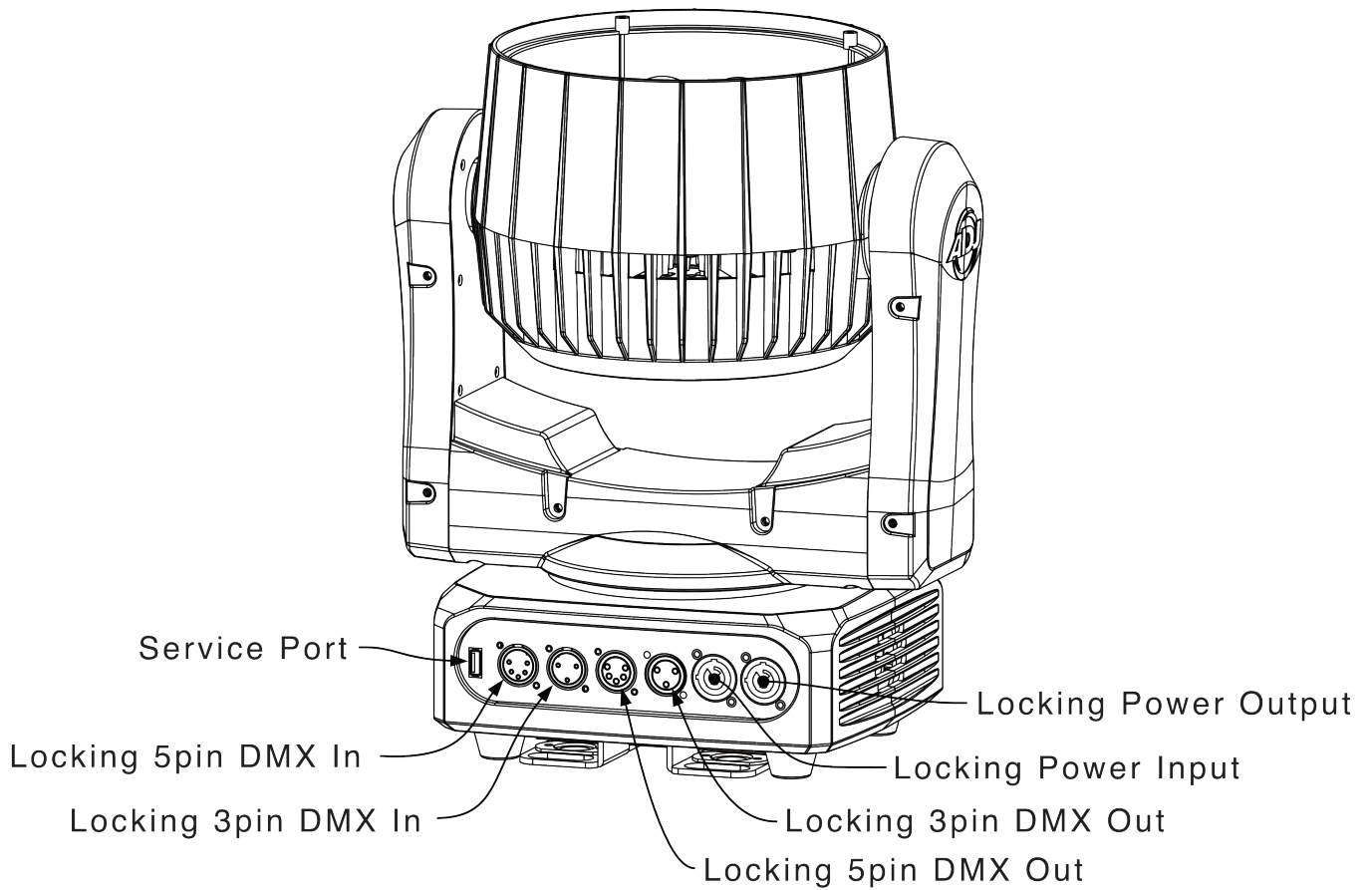
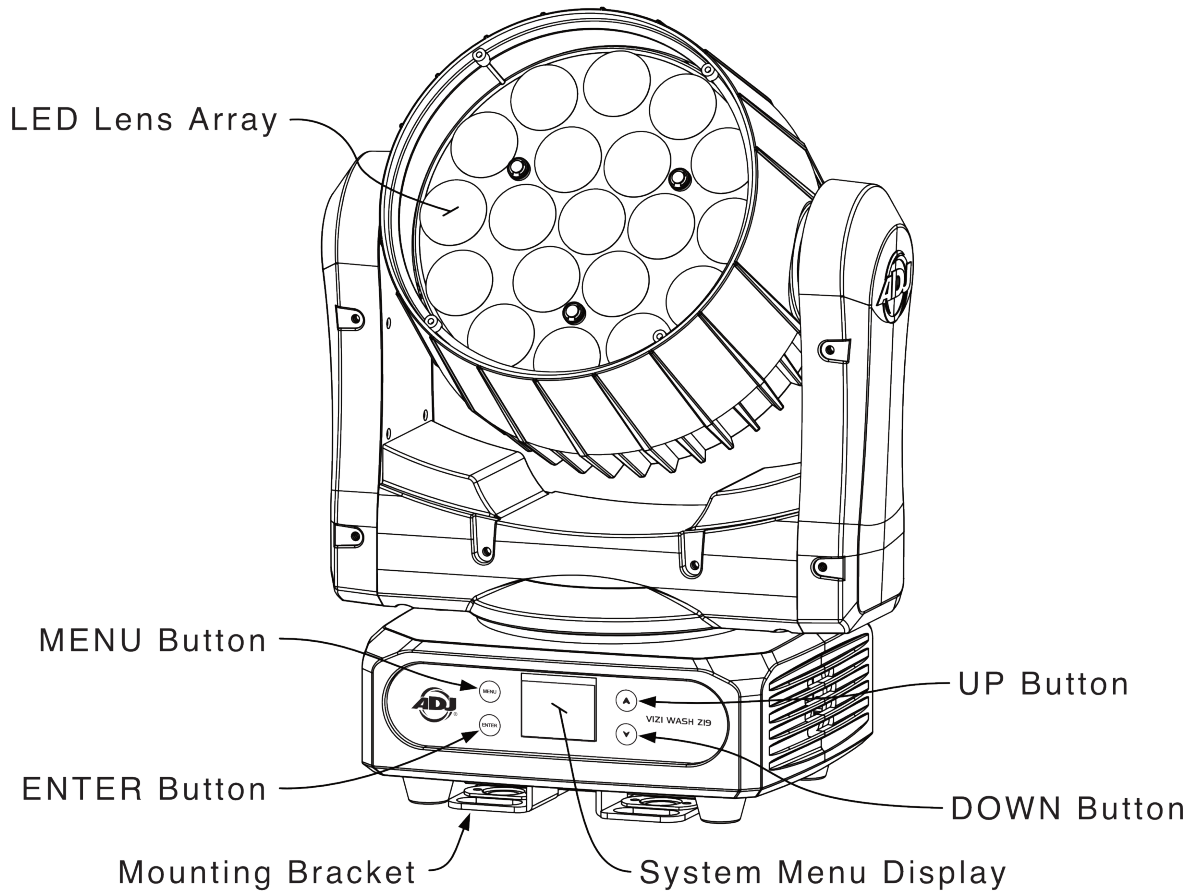

COLOR MACRO CHART

Color	DMX Value	RGBW COLOR INTENSITY				Color	DMX Value	RGBW COLOR INTENSITY			
		RED	GREEN	BLUE	W/A			RED	GREEN	BLUE	WHITE
Off	0	0	0	0	0	Color Macro 33	129-132	255	206	143	0
Color Macro 1	1-4	80	255	234	80	Color Macro 34	133-136	254	177	153	0
Color Macro 2	5-8	80	255	164	80	Color Macro 35	137-140	254	192	138	0
Color Macro 3	9-12	77	255	112	77	Color Macro 36	141-144	254	165	98	0
Color Macro 4	13-16	117	255	83	83	Color Macro 37	145-148	254	121	0	0
Color Macro 5	17-20	160	255	77	77	Color Macro 38	149-152	176	17	0	0
Color Macro 6	21-24	223	255	83	83	Color Macro 39	153-156	96	0	11	0
Color Macro 7	25-28	255	243	77	77	Color Macro 40	157-160	234	139	171	0
Color Macro 8	29-32	255	200	74	74	Color Macro 41	161-164	224	5	97	0
Color Macro 9	33-36	255	166	77	77	Color Macro 42	165-168	175	77	173	0
Color Macro 10	37-40	255	125	74	74	Color Macro 43	169-172	119	130	199	0
Color Macro 11	41-44	255	97	77	71	Color Macro 44	173-176	147	164	212	0
Color Macro 12	45-48	255	74	77	71	Color Macro 45	177-180	88	2	163	0
Color Macro 13	49-52	255	83	134	83	Color Macro 46	181-184	0	38	86	0
Color Macro 14	53-56	255	93	182	93	Color Macro 47	185-188	0	142	208	0
Color Macro 15	57-60	255	96	236	96	Color Macro 48	189-192	52	148	209	0
Color Macro 16	61-64	238	93	255	93	Color Macro 49	193-196	1	134	204	0
Color Macro 17	65-68	163	87	255	87	Color Macro 50	197-200	0	145	212	0
Color Macro 18	69-72	150	90	255	90	Color Macro 51	201-204	0	121	192	0
Color Macro 19	73-76	100	77	255	77	Color Macro 52	205-208	0	129	184	0
Color Macro 20	77-80	77	100	255	77	Color Macro 53	209-212	0	83	115	0
Color Macro 21	81-84	67	148	255	67	Color Macro 54	213-216	0	97	166	0
Color Macro 22	85-88	77	195	255	77	Color Macro 55	217-220	1	100	167	0
Color Macro 23	89-92	77	234	255	77	Color Macro 56	221-224	0	40	86	0
Color Macro 24	93-96	158	255	144	144	Color Macro 57	225-228	209	219	182	0
Color Macro 25	97-100	255	251	153	153	Color Macro 58	229-232	42	165	85	0
Color Macro 26	101-104	255	175	147	147	Color Macro 59	233-236	0	46	35	0
Color Macro 27	105-108	255	138	186	138	Color Macro 60	237-240	8	107	222	0
Color Macro 28	109-112	255	147	251	147	Color Macro 61	241-244	255	0	0	0
Color Macro 29	113-116	151	135	255	138	Color Macro 62	245-248	0	255	0	0
Color Macro 30	117-120	99	0	255	100	Color Macro 63	249-252	0	0	255	0
Color Macro 31	121-124	138	169	255	138	Color Macro 64	253-255	0	0	0	255
Color Macro 32	128-128	255	255	255	255						

INSTALLATION GUIDELINES



FLAMMABLE MATERIAL WARNING

Keep fixture minimum 0.7 feet (0.2m) away from flammable materials and/or pyrotechnics.



ELECTRICAL CONNECTIONS

A qualified electrician should be used for all electrical connections and/or installations.



USE CAUTION WHEN POWER LINKING OTHER MODEL FIXTURES AS THE POWER CONSUMPTION OF OTHER MODEL FIXTURES MAY EXCEED THE MAX POWER OUTPUT ON THIS FIXTURE. CHECK SILK SCREEN FOR MAX AMPS.



**MINIMUM DISTANCE TO OBJECTS/SURFACES
MUST BE 6.6 FEET (2 METERS)**



**MINIMUM DISTANCE OF INFLAMMABLE MATERIALS
FROM THE SURFACE 0.7 FEET (0.2 METER)**



MAXIMUM TEMPERATURE OF EXTERNAL SURFACE 167° F (75°C)

DO NOT INSTALL THE FIXTURE IF YOU ARE NOT QUALIFIED TO DO SO!

Fixture **MUST** be installed following all local, national, and country commercial electrical and construction codes and regulations.

Before rigging/mounting a single fixture or multiple fixtures to any metal truss/structure or placing the fixture(s) on any surface, a professional equipment installer **MUST** be consulted to determine if the metal truss/structure or surface is properly certified to safely hold the combined weight of the fixture(s), clamps, cables, and accessories.

Fixture ambient operating temperature range is **0° to 104°F. (0° to 40°C)**.

Do not Use fixture under or above this temperature.

Fixture(s) should be installed in areas outside walking paths, seating areas, or away from areas where unauthorized personnel might reach the fixture by hand.

NEVER stand directly below the fixture(s) when rigging, removing or servicing.

Overhead fixture installation must always be secured with a secondary safety attachment, such as an appropriately rated safety cable.

Allow approximately 15 minutes for the fixture to cool down before servicing.

RIGGING

Overhead rigging requires extensive experience, including among others calculating working load limits, installation material being used, and periodic safety inspection of all installation material and the fixture. If you lack these qualifications, do not attempt the installation yourself. Improper installation can result in bodily injury.



ALWAYS ATTACH AN APPROPRIATELY RATED SAFETY CABLE (NOT INCLUDED) THAT MEETS ALL LOCAL, NATIONAL, AND COUNTRY CODES AND REGULATIONS WHENEVER INSTALLING FIXTURE IN A SUSPENDED ENVIRONMENT!

INSTALLATION GUIDELINES

OMEGA BRACKETS INSTALLATION

Insert the Omega Brackets into the matching holes on the bottom of the fixture. Secure the Omega Brackets to the fixture by turning each quick-lock fastener ¼ turn clockwise; making sure the fastener is completely locked. Omega Brackets can be installed into the fixture base as illustrated below.

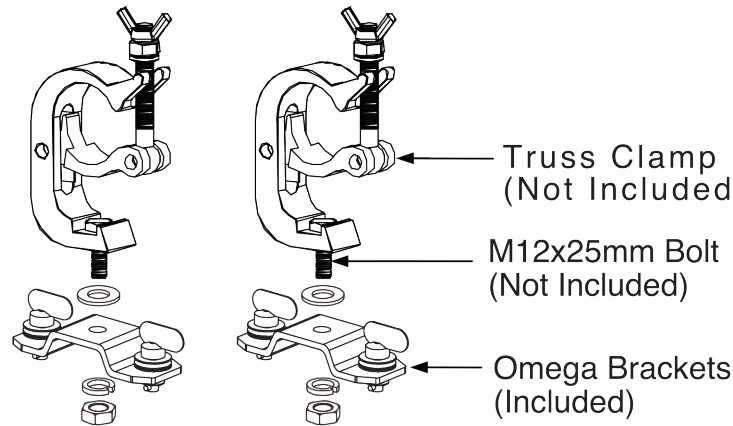

**SAFETY CABLE
ALWAYS ATTACH A SAFETY
WHENEVER INSTALLING THIS
FIXTURE IN A SUSPENDED
ENVIRONMENT TO ENSURE
THE FIXTURE WILL NOT FALL
IF THE CLAMP FAILS.**

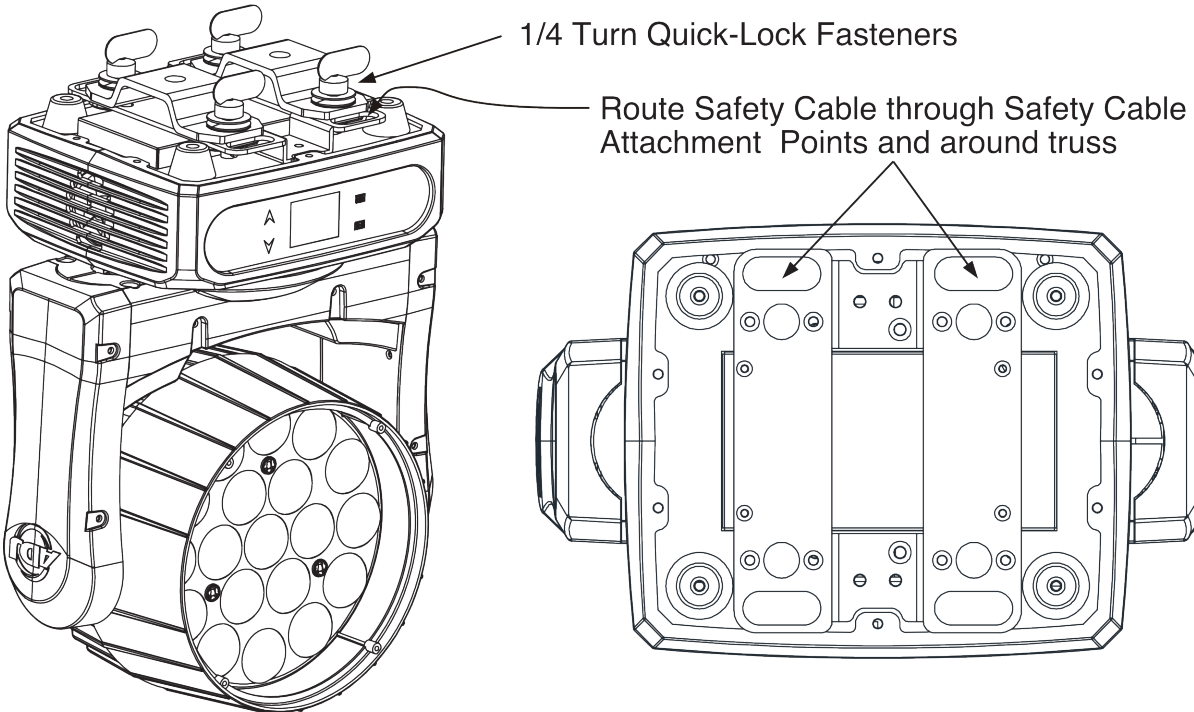

CLAMP INSTALLATION

When mounting fixture to truss, be sure to secure an appropriately rated professional grade rigging clamp to the included **Omega Brackets** using an M12 screw fitted through the center hole of the **Omega Brackets**. The fixture provides built-in rigging points for a **SAFETY CABLE** (not included). Be sure to only use one of the designated rigging points for the safety cable and never secure a safety cable to a carrying handle.

INSTALLATION GUIDELINES

RIGGING

Overhead rigging requires extensive experience, including among others, calculating working load limits, installation material being used, and periodic safety inspection of all installation material and the fixture. If you lack these qualifications, do not attempt the installation yourself. Improper installation can result in bodily injury.

This fixture is designed to be mounted vertically (hanging or upright), or horizontally (perpendicular to vertical axis) only.

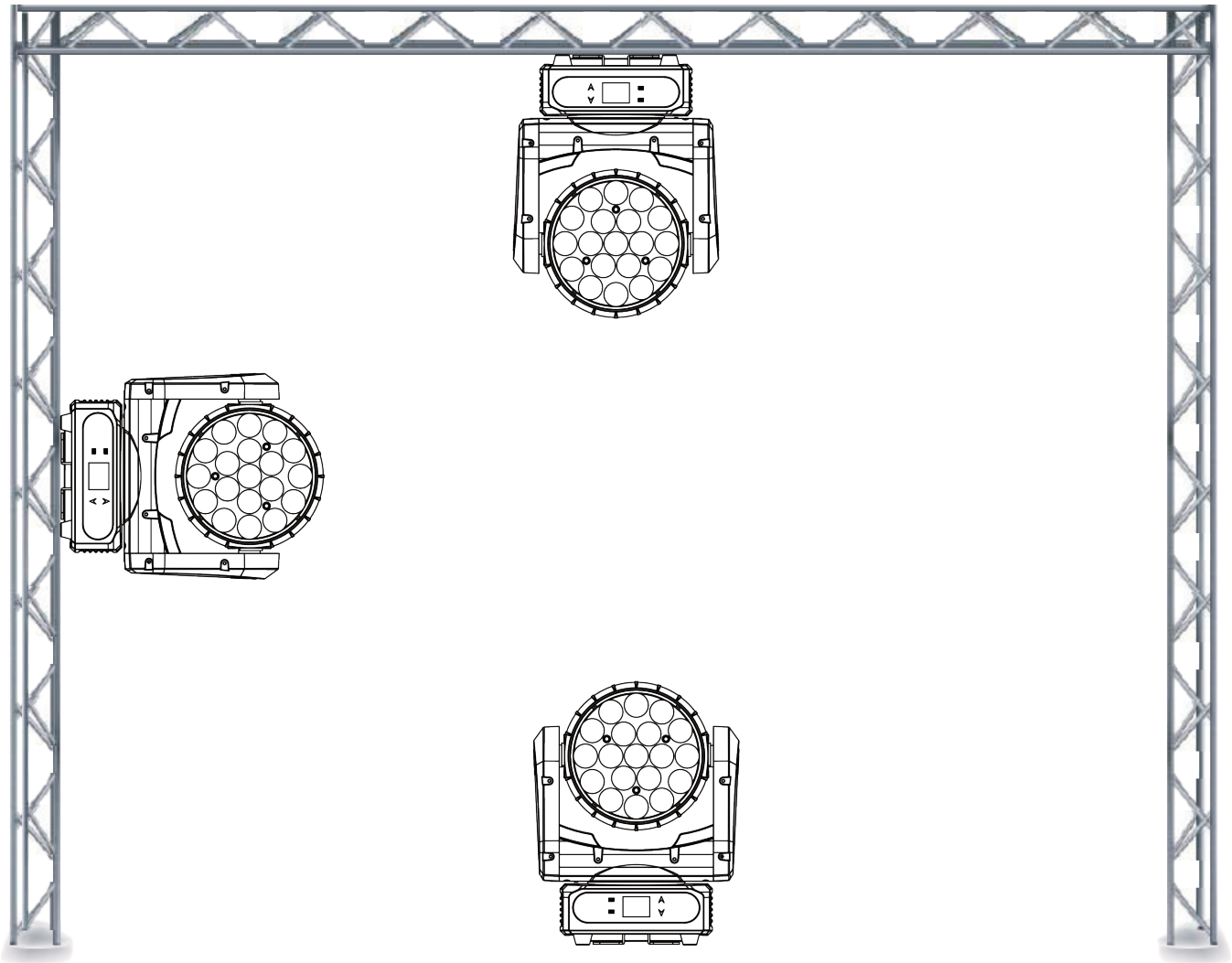

DMX SETUP

DMX-512: DMX is short for Digital Multiplex. This is a universal protocol used as a form of communication between intelligent fixtures and controllers. A DMX controller sends DMX data instructions from the controller to the fixture. DMX data is sent as serial data that travels from fixture to fixture via the DATA “IN” and DATA “OUT” XLR terminals located on all DMX fixtures (most controllers only have a DATA “OUT” terminal).

DMX Linking: DMX is a language allowing all makes and models of different manufactures to be linked together and operate from a single controller, as long as all fixtures and the controller are DMX compliant. To ensure proper DMX data transmission, when using several DMX fixtures try to use the shortest cable path possible. The order in which fixtures are connected in a DMX line does not influence the DMX addressing. For example; a fixture assigned a DMX address of 1 may be placed anywhere in a DMX line, at the beginning, at the end, or anywhere in the middle. When a fixture is assigned a DMX address of 1, the DMX controller knows to send DATA assigned to address 1 to that unit, no matter where it is located in the DMX chain.

Data Cable (DMX Cable) Requirements (For DMX Operation): The Focus Flex can be controlled via DMX-512 protocol. Your unit and your DMX controller requires a 5-pin XLR connector for data input/output. We recommend Accu-Cable DMX cables. If you are making your own cables, be sure to use standard 110-120 Ohm shielded cable (This cable may be purchased at almost all pro lighting stores). Your cables should be made with a male and female XLR connector on either end of the cable. Also remember that DMX cable must be daisy chained and cannot be split.



Notice: Be sure to follow figures two and three when making your own cables. Do not use the ground lug on the XLR connector. Do not connect the cable’s shield conductor to the ground lug or allow the shield conductor to come in contact with the XLR’s outer casing. Grounding the shield could cause a short circuit and erratic behavior.

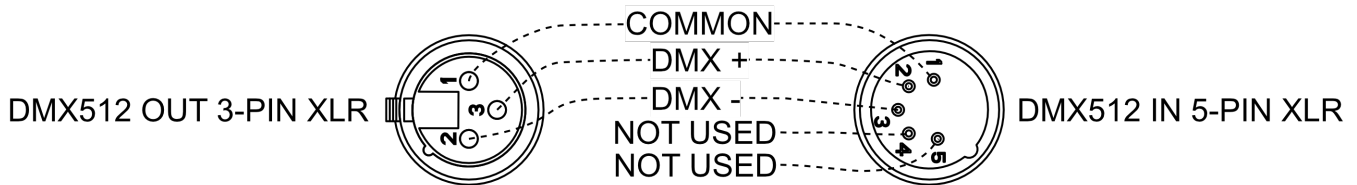

3-Pin XLR to 5-Pin XLR Conversion		
Ground/Shield	Pin 1	Pin 1
Data Compliment (- signal)	Pin 2	Pin 2
Data True (+ signal)	Pin 3	Pin 3
Not Used		Do Not Use
Not Used		Do Not Use

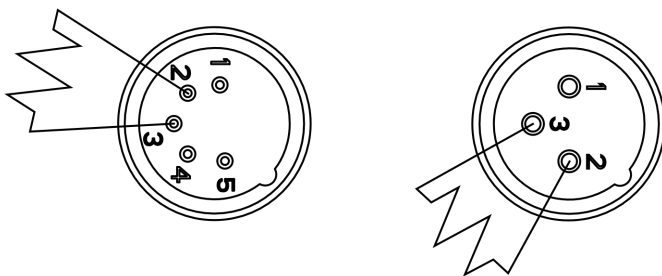

A DMX512 terminator reduces signal errors, avoiding most signal reflection interference. Connect PIN 2 (DMX-) and PIN 3 (DMX+) of the last fixture in series with a 120 Ohm, 1/4 W Resistor to terminate the DMX512.

Special Note: Line Termination. When longer runs of cable are used, you may need to use a terminator on the last unit to avoid erratic behavior. A terminator is a 110-120 ohm 1/4 watt resistor which is connected between pins 2 and 3 of a male XLR connector (DATA + and DATA -). This unit is inserted in the female XLR connector of the last unit in your daisy chain to terminate the line. Using a cable terminator (ADJ part number Z-DMX/T) will decrease the possibilities of erratic behavior.

DMX ADDRESSING

All fixtures should be given a DMX starting address when using a DMX controller, so the correct fixture responds to the correct control signal. This digital starting address is the channel number from which the fixture starts to “listen” to the digital control signal sent out from the DMX controller. The assignment of this starting DMX address is achieved by setting the correct DMX address on the digital control display on the fixture.

You can set the same starting address for all fixtures or a group of fixtures, or set different addresses for each individual fixture. Setting all fixtures to the same DMX address will cause all fixtures to react in the same way, in other words, changing the settings of one channel will affect all the fixtures simultaneously.

If you set each fixture to a different DMX address, each unit will start to “listen” to the channel number you have set, based on the quantity of DMX channels of each fixture. That means changing the settings of one channel will only affect the selected fixture.

In the case of the Vizi Wash Z19, when in 13 Channel you should set the starting DMX address of the first unit to 1, the second unit to 14 (13 + 1), the third unit to 27 (14 + 13), and so on. (See the charts below for more details.)

Channel Mode	Unit 1 Address	Unit 2 Address	Unit 3 Address	Unit 4 Address
13 Channels	1	14	27	40
14 Channels	1	15	29	43
17 Channels	1	18	35	52
18 Channels	1	19	37	55
29 Channels	1	30	59	88
30 Channels	1	31	61	91
45 Channels	1	46	91	136
46 Channels	1	47	93	139

SYSTEM MENU

The fixture includes an easy to navigate system menu control panel display where all necessary settings and adjustments are made. (See image below) During normal operation, pressing the **MENU** button once will access the fixture's main menu. Once in the main menu, you can navigate through the different functions and access the sub-menus with the **UP** and **DOWN** buttons. When you reach a field that requires adjusting, press the **ENTER** button to access that field and use the **UP** and **DOWN** buttons to adjust the field. Pressing the **ENTER** button once more will confirm your setting. You may exit the main menu at any time without making any adjustments by pressing the **MENU** button.

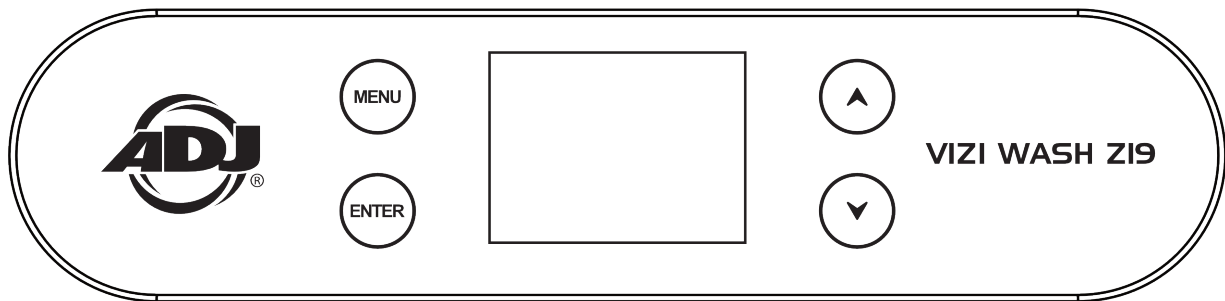

SYSTEM MENU

ADJ VIZI WASH Z19 - SYSTEM MENU					
Default setting shown in bold					
MAIN MENU	OPTIONS / VALUES (Default Settings in BOLD)			DESCRIPTION	
DMX Settings	DMX Address	001 - 512		Shall be used to set the units starting DMX address channel. Depending on set DMX mode, unit shall not allow to be addressed any higher that will not allow for all channels to be accessed from the console.	
	DMX CH Mode	Mode1(13), Mode2(14), Mode3(17), Mode4(18), Mode5(29), Mode6(30), Mode7(45), & Mode8(46)		Shall be used to set the units desired DMX mode.	
	No DMX Status	Hold Last		Shall be used to set the units behavior when DMX signal is not present. Hold shall be the default setting and unit shall hold all last channel values received from the console when signal is lost.	
		Blackout		Blackout option shall take all channels to zero (0) when signal is lost.	
		Int. Pro.			
Manual		Manual Settings option shall take all channels to the last set Manual channel settings when signal is lost.			
Personality	Status Settings	Pan Invert	ON / OFF		
		Tilt Invert	ON / OFF		
		P./T. Feedback	ON / OFF		
		P./T. Speed	Speed 1 , Speed 2	Speed 1 (Default) should allow unit to move at its fastest possible speed without losing step. Speed 2 should be for more smooth precise movements so naturally this would be slower movements compared to Speed 1	
		Hibernation	OFF, 01M~99M, 15M	When DMX signal is not present for the set time, the unit shall go into standby mode after the set time. When set to OFF, unit shall never go into hibernation mode. The unit should have 01M to 99M options... so 01M, 02M, 03M... 99M (M=Minutes). 15M should be default.	
	Fan Settings	Head	Auto , High, Silent		
		Base	Auto , High, Silent		
	Dim Modes	Standard , Stage, TV, Architectural, Theatre, Stage 2			Preset dim modes... see Dim Modes Tab for details.
		Dim Speed	0.1S~10S		Set your own dim delay versus smooth dimming. 0.1s is the least delay, and 10s is the most delay.
	Dim Curve	Square Law , Linear, Inv SQ Law, S.Curve			
	Reset Motors	Pan/Tilt	YES / NO		
		Effect	YES / NO		
		All	YES / NO		
	Display	Backlight Intensity	1-10		
		Display Invert	YES / NO		
Screen Saver Delay		OFF - 10 minutes			
Display Lock ON/OFF		ON / OFF			

SYSTEM MENU

MAIN MENU	OPTIONS / VALUES (Default Settings in BOLD)		DESCRIPTION			
<p>Personality</p>	<p>Service</p>	<p>Calibration</p>	<p>Pan 128-127</p> <p>Tilt 128-127</p> <p>Zoom 0-255</p> <p>Red 125-255</p> <p>Green 125-255</p> <p>Blue 125-255</p> <p>White 125-255</p> <p>Red1 125-255</p> <p>Green1 125-255</p> <p>Blue1 125-255</p> <p>White1 125-255</p> <p>...</p> <p>Red7 125-255</p> <p>Green7 125-255</p> <p>Blue7 125-255</p> <p>White7 125-255</p>			
			<p>USB Port Power</p>	<p>ON / OFF</p>		
			<p>Update Software</p>	<p>YES / NO</p>		
			<p>Factory Restore</p>	<p>YES / NO</p>	<p>When “YES” is selected, enter password (password = 11) to reset the fixture to factory settings.</p>	
			<p>Manual Control</p>	<p>Pan</p>	<p>000-255</p>	<p>Manual control settings shall always hold when no DMX signal is present. This includes after a power cycle.</p>
				<p>Tilt</p>	<p>000-255</p>	
				<p>Red1-7</p>	<p>000-255</p>	
				<p>Blue1-7</p>	<p>000-255</p>	
				<p>Green1-7</p>	<p>000-255</p>	
				<p>White1-7</p>	<p>000-255</p>	
				<p>Color</p>	<p>000-255</p>	
				<p>Shutter</p>	<p>000-255</p>	
				<p>Dimmer</p>	<p>000-255</p>	
				<p>Zoom</p>	<p>000-255</p>	
<p>Special Function</p>	<p>000-255</p>					

SYSTEM MENU

MAIN MENU	OPTIONS / VALUES (Default Settings in BOLD)			DESCRIPTION	
Internal Programs	Program 0	Speed	000-255	Shall run the set program based on this speed setting, 000 being slowest and 255 being the fastest... unless the Sound function is set to ON, which takes priority. Program 0 shall randomly cycle through all available programs, automatically changing every 30 to 45 seconds.	
		Fade	000-255	Shall run the set program based on this fade setting, 000 being NO fade and 255 being maximum fade.	
	Program 1	Speed	000-255	Shall run the set program based on this speed setting, 000 being slowest and 255 being the fastest.	
		Fade	000-255	Shall run the set program based on this fade setting, 000 being NO fade and 255 being maximum fade.	
	Program 2	Speed	000-255	Shall run the set program based on this speed setting, 000 being slowest and 255 being the fastest.	
		Fade	000-255	Shall run the set program based on this fade setting, 000 being NO fade and 255 being maximum fade.	
	Program 3	Speed	000-255	Shall run the set program based on this speed setting, 000 being slowest and 255 being the fastest.	
		Fade	000-255	Shall run the set program based on this fade setting, 000 being NO fade and 255 being maximum fade.	
	Program 4	Speed	000-255	Shall run the set program based on this speed setting, 000 being slowest and 255 being the fastest.	
		Fade	000-255	Shall run the set program based on this fade setting, 000 being NO fade and 255 being maximum fade.	
	Target Mode	Mode0			
		Mode1			
		Mode2			
		Mode3			
Mode4					

SYSTEM MENU

MAIN MENU	OPTIONS / VALUES (Default Settings in BOLD>)			DESCRIPTION	
Information	Fixture Life Time	Power On Time	xxxxxx Hours	Total hrs. fixture powered ON. Cannot be reset.	
		P-On Time-R	xxxxxx Hours	Hours fixture powered ON. Can be reset	
		P-On Time Reset	Passcode	Reset Power On Time (Passcode = 050)	
	Total LED Time	LED On Time	xxxxxx Hours	Resets to 0 when lamp replaced and reset (Passcode = 050)	
		LED On Time-R	xxxxxx Hours		
		LED On Time Reset	Passcode		
	Fixture Temps	LEDs	Current	xxx F°/ xxx C°	Current temperature in Farenheit and Celsius
			Max Resettable	xxx F°/ xxx C°	Current maximum temperature since last reset. Can be reset as needed by user.
			Max Not Resettable	xxx F°/ xxx C°	Maximum temperature fixture reached. Cannot be reset
		Reset LED Temp	YES / NO	Passcode	Shall allow for Head Temperature data to be reset. Should be Passcode protected (Passcode = 050).
	Fan Info.(RPM)	Base Fan XXXX	xxxx	Displays fan RPM	
		LED Fan XXXX	xxxx		
	DMX Values	Pan		Displays current DMX Channel value of respective fixture trait.	
		Tilt			
		...			
Zoom					
Error Logs	Fixture Errors	List Errors one by one	Displays Fixture Errors		
	Reset Error Log	YES / NO	Reset Error Log (Passcode = 050)		
Max Temp LED ON	32~167°F, 118°F / 0~75°C, 48°C				
High Temp LED OFF	169°F, 117°F / 76°C, 47°C				
Software Version	X.XX				

SYSTEM MENU

DMX Settings

Select **DMX Settings**, and press **ENTER** button to confirm. Use **UP/DOWN** buttons to select **DMX Address**, **DMX Channel Mode**, or **No DMX Status**.

- **DMX Address** — DMX512 address setting
Select **DMX Address**, and press **ENTER** button to confirm. Use **UP/DOWN** buttons to adjust address from **001** to **512**, and press **ENTER** button to store.
- **DMX Channel Mode** — channel mode
Select **DMX Channel Mode**, and press **ENTER** button to confirm. Use **UP/DOWN** buttons to select [(Mode1(13), Mode2(14), Mode3(17), Mode4(18), Mode5(29), Mode6(30), Mode7(45), & Mode8(46)], and press **ENTER** button to store.
- **No DMX Status** — fixture state while DMX single stops
Select **No DMX Status**, and press **ENTER** button to confirm. Use **UP/DOWN** buttons to select **Hold Last** (If DMX signal stops, fixture continues to obey the last command it received Via DMX), **Int. Pro.**, **Blackout** (fixture blacks-out if DMX signal stops), or **Manual** (If DMX signal stops, fixture returns all channels to the last setting entered manually), and press **ENTER** button to store.

In the **Blackout / Hold Last** state, and with no DMX signal, the unit will remain in the final state for 15M before reverting to static mode. At this time, the lamp and motors will turn-off. When the DMX signal is reconnected, the unit will automatically activate and reset.:

- **Hold Last** -This setting will have the fixture stay in the last DMX setup.
- **Blackout** - This setting will have the fixture automatically go into stand by mode (blackout).
- **Internal Programs** - This setting will have the fixture run an internal program.
- **Manual** -This setting will have the fixture automatically go to the setup made under the “**Manual Control**” menu. See **MANUAL Control** below.

SYSTEM MENU

Personality

Select Personality, and press **ENTER** button to confirm, use **UP/DOWN** buttons to select **Status Settings**, **Fan Settings**, **Dim Modes**, **Dim Curves**, **Reset Motors**, **Display**, or **Service**.

Status Settings

Select **Status Settings**, and press **ENTER** button to confirm. Use **UP/DOWN** buttons to select **Pan Invert**, **Tilt Invert**, **P./T. Feedback**, **P./T. Speed**, or **Hibernation**, and press **ENTER** button to store.

Fan Settings

Select **Fan Settings**, and press **ENTER** button to confirm. Use **UP/DOWN** buttons to select **Head**, or **Base**, and press **ENTER** button to store.

Dim Modes

Select Tilt Invert, and press **ENTER** button to confirm. Use **UP/DOWN** buttons to select **Standard**, **Stage**, **TV**, **Architectural**, **Theatre**, **Stage 2**, or **Dim Speed**, and press **ENTER** button to store.

Dim Curve

Select P./T. Feedback, and press **ENTER** button to confirm. Use **UP/DOWN** buttons to select **Square law**, **Linear**, **Inv. SQ law**, or **S Curve**, and press **ENTER** button to store.

Reset Motors

Select **Reset Motors**, and press **ENTER** button to confirm. Use **UP/DOWN** buttons to select **Pan/Tilt**, **Effect**, or **All**, and press **ENTER** button to store.

Display

Select **Display**, and press **ENTER** button to confirm. Use **UP/DOWN** buttons to select **Backlight Intensity**, **Display Invert**, **Screen Saver Delay**, or **Display Lock ON/OFF**, and press **ENTER** button to store.

Service

Select **Service**, and press **ENTER** button to confirm. Current mode will show on the display, Use **UP/DOWN** button to select **050**, and press **ENTER** button to confirm. Use **UP/DOWN** buttons to select **Calibration**, **USB Port Power**, **Update Software**, or **Factory Restore** (password=11).

When selecting **Calibration**, use **UP/DOWN** buttons to select **Pan**, **Tilt**, **Zoom**, **Red**, **Green**, **Blue**, **White**, **Red1**, **Green1**, **Blue1**, **White1**.....**Red7**, **Green7**, **Blue7**, and **White7**, then use **UP** and **DOWN** button to adjust value.

When selecting **USB Port Power**, use **UP/DOWN** buttons to select **OFF** or **ON**.

When selecting **Update Software**, Use **UP/DOWN** buttons to select **NO** or **YES**.

When selecting **Factory Restore**, use **UP/DOWN** buttons to select **NO** or **YES**. When “**YES**” is selected, enter password (password=11) to reset the fixture to factory settings.

SYSTEM MENU

Manual Control

Select **Manual Control**, and press **ENTER** button to confirm. Current channel will show on the display. Use **UP/DOWN** button to select **Pan, Tilt, Red1-7, Blue1-7, Green1-7, White1-7, Color, Shutter, Dimmer, Zoom, or Special Function**, press **ENTER** button to confirm, then Use **UP/DOWN** button to adjust value **000** to **255**, press **ENTER** button to store, and the fixture will run as the channel value indicates. Press **MENU** button back to the last menu, or exit menu mode idling one minute.

(All channels value will become 0 after exiting Manual Test menu)

Internal Program

Select **Internal Program**, and press **ENTER** button to confirm. Use **UP/DOWN** buttons to select **Program 0, Program 1, Program 2, or Program 3**.

Target Mode

Select **Target Mode**, and press **ENTER** button to confirm. Use **UP/DOWN** buttons to select **Mode0, Mode1, Mode2, Mode3, or Mode4**.

Information

Select **Information**, and press **ENTER** button to confirm. Use **UP/DOWN** buttons to select **Fixture Life Time, Total LED Time, Fixture Temps, Fan Info.(RPM), DMX Values, Error Logs, Max Temp LED ON, High Temp LED OFF, or Software Version**.

Fixture Life Time

Select **Fixture Life Time**, and press **ENTER** button to confirm. Use **UP/DOWN** buttons to select **Power On Time, P-On Time-R, or P-On Time Reset**, and press **ENTER** button to store.

Total LED Time

Select **Total LED Time**, and press **ENTER** button to confirm. Use **UP/DOWN** buttons to select **LED On Time, LED On Time-R, or LED On Time Reset**, and press **ENTER** button to store.

Fixture Temperatures

Select **Fixture Temps**, and press **ENTER** button to confirm. Use **UP/DOWN** buttons to select **LEDs, or Reset LED Temp**, and press **ENTER** button to store.

Fan Info.(RPM)

Select **Fan Info.(RPM)**, and press **ENTER** button to confirm. Use **UP/DOWN** buttons to select **Base Fan, LED Fan**, and press **ENTER** button to store.

DMX Values

Select **DMX Values**, and press **ENTER** button to confirm. Use **UP/DOWN** buttons to select **Pan, Tilt, ..., or Zoom**, and press **ENTER** button to store.

Error Logs

Select **Error Logs**, and press **ENTER** button to confirm. Use **UP/DOWN** buttons to select **Fixture Errors, or Reset Error Log**, and press **ENTER** button to store.

Max Temp LED ON

Select **Max Temp LED ON**, and press **ENTER** button to confirm. **32~167°F, 118°F / 0~75°C, 48°C** will show. Press **MENU** button to exit.

High Temp LED OFF

Select **High Temp LED OFF**, and press **ENTER** button to confirm. **169°F, 117°F / 76°C, 47°C** will show. Press **MENU** button to exit.

Software Version

Select **Software Version**, and press **ENTER** button to confirm. **Software Version** will show on the display. Press **MENU** button to exit.

PIXEL ZONE LAYOUT

Pixel Zone Layout
28 Ch. Mode (29 Ch. Mode w/ Software Version ≥ 1.6)

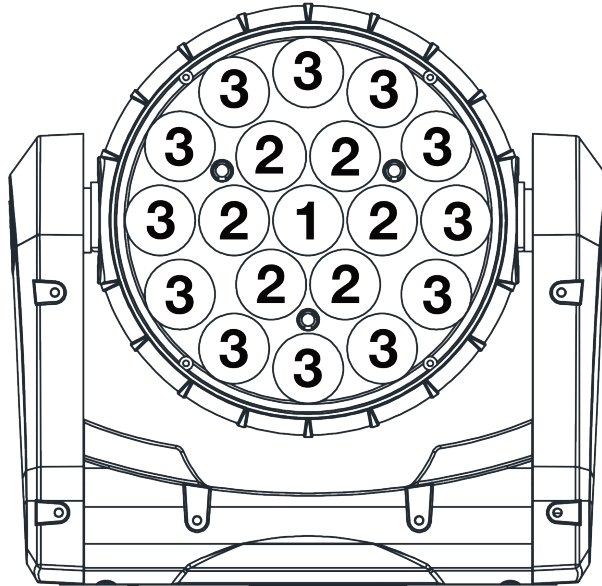

Pixel Zone Layout
44 Ch. Mode (45 Ch. Mode w/ Software Version ≥ 1.6)

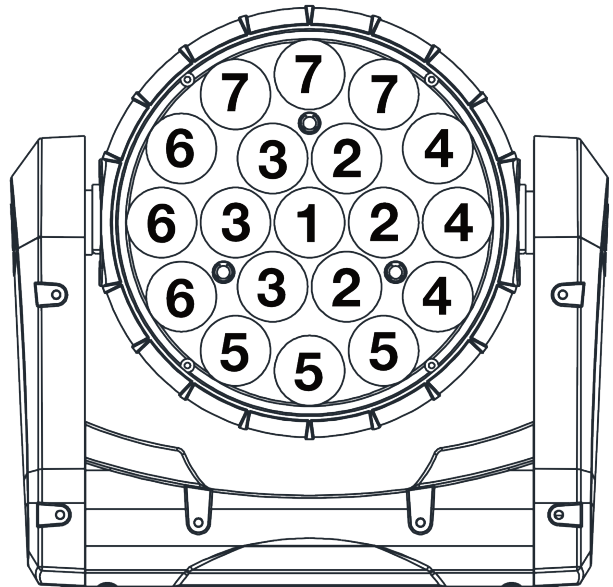
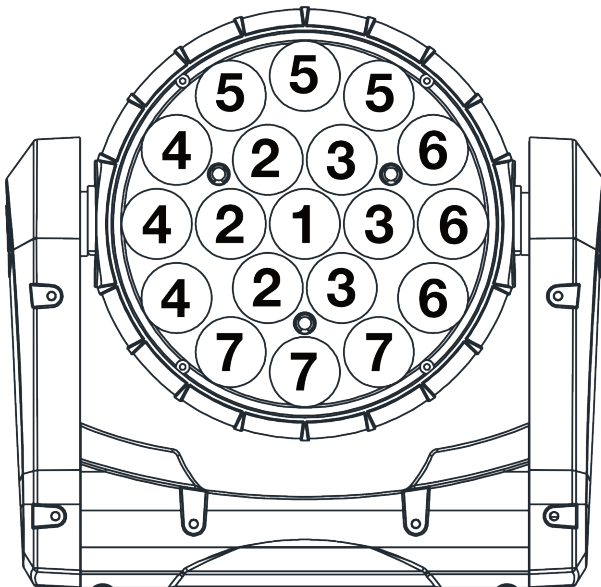

TARGET MODES

Mode 0 Pan Movement Range = 540°

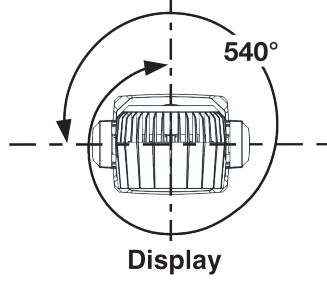

Tilt Movement Range = 270°

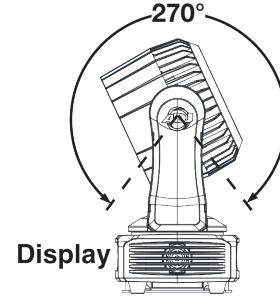

Mode 1 Pan Movement Range = 90°

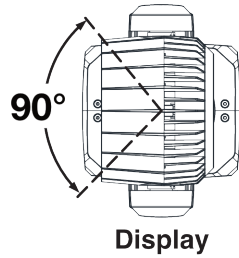

Tilt Movement Range = 135°

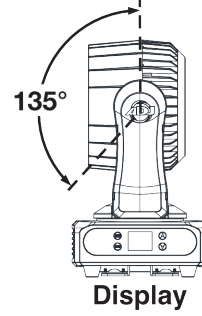

Mode 2 Pan Movement Range = 90°

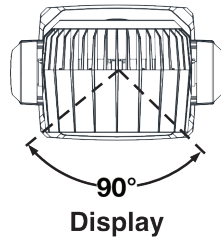

Tilt Movement Range = 135°

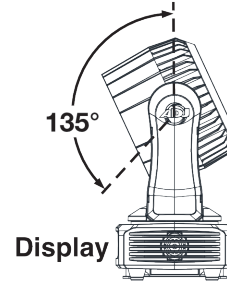

Mode 3 Pan Movement Range = 90°

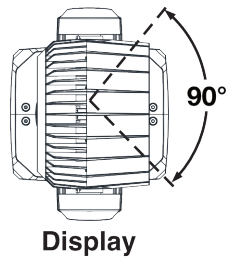

Tilt Movement Range = 135°

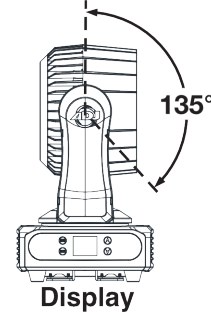

Mode 4 Pan Movement Range = 90°

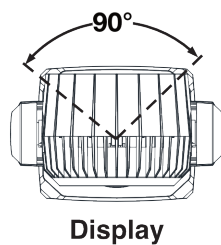

Tilt Movement Range = 135°

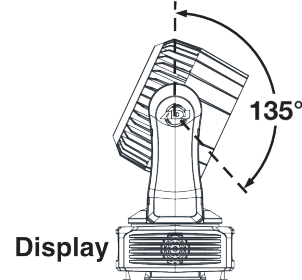

DIMMER MODE GRAPHS

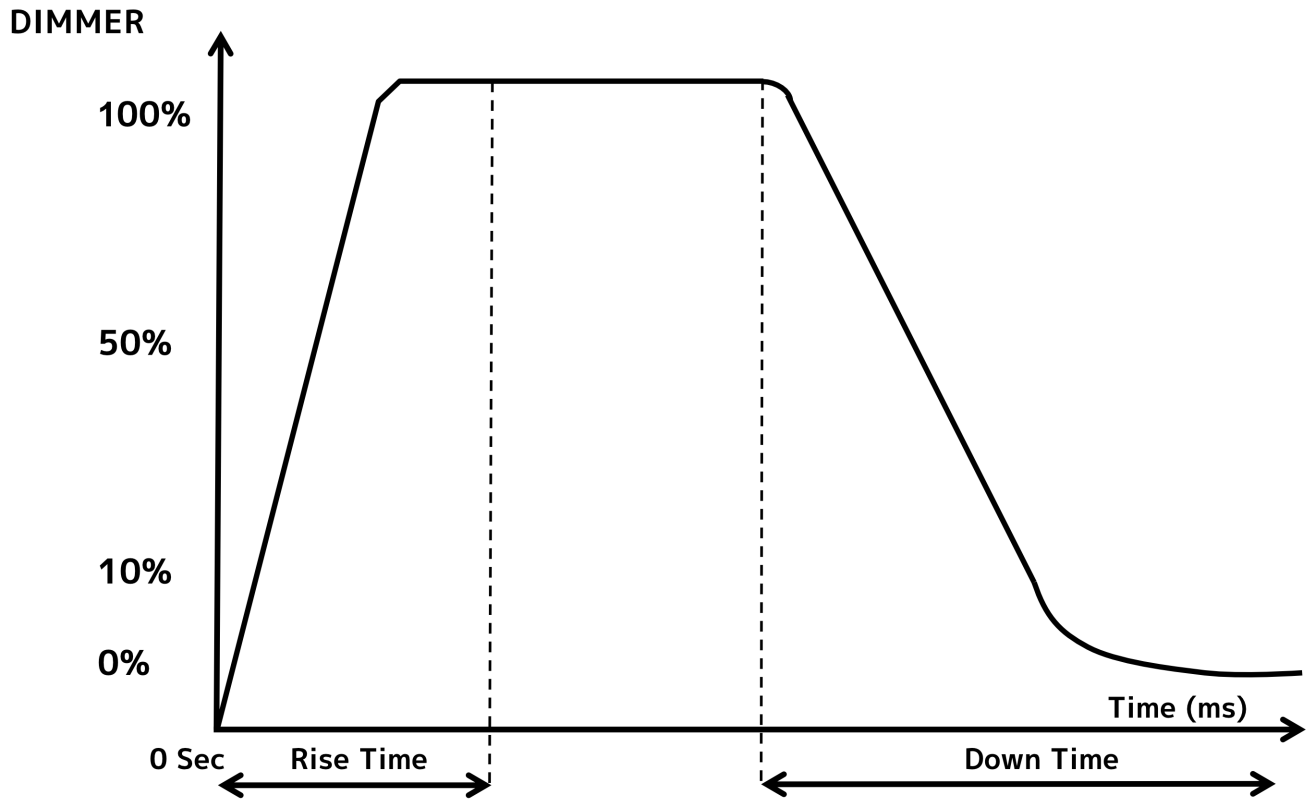

Dimming Curve Ramp Effect	0 sec Fade Time		1 sec Fade Time	
	Rise Time (ms)	Down Time (ms)	Rise Time (ms)	Down Time (ms)
Standard (default)	0	0	0	0
Stage	780	1100	1540	1660
TV	1180	1520	1860	1940
Architectural	1380	1730	2040	2120
Theatre	1580	1940	2230	2280

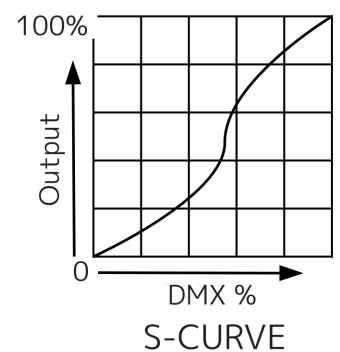
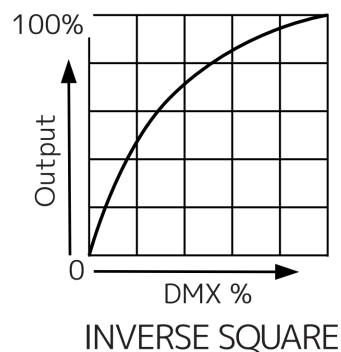
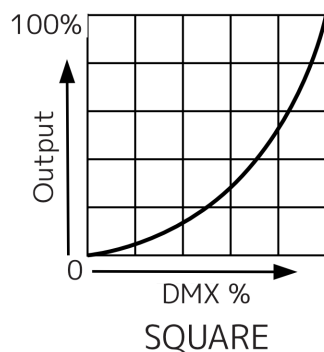
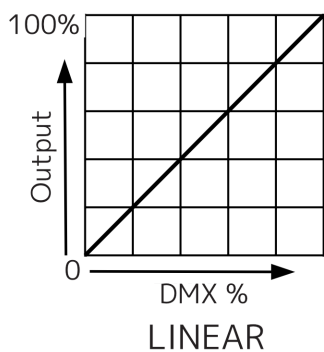

DMX TRAITS: CHANNEL FUNCTIONS & VALUES

Features subject to change without notice.

MODE/CHANNEL								VALUE	FUNCTION
13CH	14CH	17CH	18CH	29CH	30CH	CH45	46CH		
1	1	1	1	1	1	1	1	000-255	PAN Movement 8bit: 540 Degrees
		2	2	2	2	2	2	000-255	Pan Fine 16bit: Fine control of Pan movement:
2	2	3	3	3	3	3	3	000-255	TILT Movement 8bit: 224 Degrees:
		4	4	4	4	4	4	000-255	Tilt Fine 16bit: Fine control of Tilt movement
3	3	5	5	5	5	5	5	000-255	Red: Dimmer 0% - 100%
4	4	6	6	6	6	6	6	000-255	Green: Dimmer 0% - 100%
5	5	7	7	7	7	7	7	000-255	Blue: Dimmer 0% - 100%
6	6	8	8	8	8	8	8	000-255	White: Dimmer 0% - 100%
				9	9	9	9	000-255	Red2: Dimmer 0% - 100%
				10	10	10	10	000-255	Green2: Dimmer 0% - 100%
				11	11	11	11	000-255	Blue2: Dimmer 0% - 100%
				12	12	12	12	000-255	White2: Dimmer 0% - 100%
				13	13	13	13	000-255	Red3: Dimmer 0% - 100%
				14	14	14	14	000-255	Green3: Dimmer 0% - 100%
				15	15	15	15	000-255	Blue3: Dimmer 0% - 100%
				16	16	16	16	000-255	White3: Dimmer 0% - 100%
						17	17	000-255	Red4: Dimmer 0% - 100%
						18	18	000-255	Green4: Dimmer 0% - 100%
						19	19	000-255	Blue4: Dimmer 0% - 100%
						20	20	000-255	White4: Dimmer 0% - 100%
						21	21	000-255	Red5: Dimmer 0% - 100%
						22	22	000-255	Green5: Dimmer 0% - 100%
						23	23	000-255	Blue5: Dimmer 0% - 100%
						24	24	000-255	White5: Dimmer 0% - 100%
						25	25	000-255	Red6: Dimmer 0% - 100%
						26	26	000-255	Green6: Dimmer 0% - 100%
						27	27	000-255	Blue6: Dimmer 0% - 100%
						28	28	000-255	White6: Dimmer 0% - 100%
						29	29	000-255	Red7: Dimmer 0% - 100%
						30	30	000-255	Green7: Dimmer 0% - 100%
						31	31	000-255	Blue7: Dimmer 0% - 100%
						32	32	000-255	White7: Dimmer 0% - 100%
7	8	9	9	17	17	33	33	000-255	Color Temperature: 2700-7000K Linear
8	7	10	10	18	18	34	34	000-255	64 Color Macros (See Color Macros Chart)

Features subject to change without notice.

MODE/CHANNEL								VALUE	FUNCTION
13CH	14CH	17CH	18CH	29CH	30CH	CH45	46CH		
				19	19	35	35		Chase Patterns:
								001-014	Off
								015-030	Chase 1
								031-046	Chase 2
								047-062	Chase 3
								063-078	Chase 4
								079-094	Chase 5
								095-110	Chase 6
								111-126	Chase 7
								127-142	Chase 8
								143-158	Chase 9
								159-174	Chase 10
								175-190	Chase 11
								191-206	Chase 12
								207-222	Chase 13
								223-238	Chase 14
								239-255	Chase 15
				20	20	36	36		Chase Speed:
								000-125	Fast to Slow Backward
								126-130	Stop (Speed=0)
								131-255	Slow to Fast Forward
				21	21	37	37	000-255	Chase Fade: Fade Chase
									Shutter
								000-019	Blackout
								020-024	Open
								025-064	Strobe Slow to Fast
								065-069	Open
								070-084	Pulse Slow Open, Fast Closed
								085-089	Open
								090-104	Pulse Fast Open, Slow Closed
								105-109	Open
								110-124	Random Strobe
								125-129	Open
								130-144	Random Pulse Open
								145-149	Open
								150-164	Random Pulse Closed
								165-169	Open
								170-184	Burst Pulse
								185-189	Open
								190-204	Random Burst Pulse
								205-209	Open
								210-224	Shutter Strobe Pulse
								225-229	Open
								230-244	Burst
								245-255	Open
									Shutter, Strobe:
								000-031	Shutter Closed(LEDs OFF)
								032-063	Shutter OPEN(LEDs ON)
								064-095	Strobe effect slow to fast
								096-127	Shutter OPEN(LEDs ON)
								128-159	Pulse effect in sequences
								160-191	Shutter OPEN(LEDs ON)
								192-223	Random strobe effect slow to fast
								224-247	Shutter OPEN(LEDs ON)
								248-255	Open
9		11	11	22	22	38	38		

Features subject to change without notice.

MODE/CHANNEL								VALUE	FUNCTION
13CH	14CH	17CH	18CH	29CH	30CH	CH45	46CH		
	10							000-255	Dimmer: 0%~100%
10		12	12	23	23	39	39	000-255	Dimmer Intensity: Intensity 0 to 100%
		13	13	24	24	40	40	000-255	Dimmer Fine: Dimmer Intensity fine
11	12	14	14	25	25	41	41	000-255	Zoom: Zoom adjustment from wide to narrow
				26	26	42	42	000-255	Zoom Fine: Zoom adjustment Fine
									Dim Modes:
								000-020	Default to Unit Setting
								021-040	Standard
								041-060	Stage
								061-080	TV
	11	15	15	27	27	43	43	081-100	Architectural
								101-120	Theatre
								121-140	Stage 2
								141-160	Dim Speed from Fast to Slow (0.1-10s)
								161-255	Default to Unit Setting
									Dim Curves:
								000-020	Square
			16		28		44	021-040	Linear
								041-060	Inv. Squa
								061-080	S. Curve
								081-255	No Function
12	13	16	17	28	29	44	45	000-255	Pan/Tilt Speed: Max to Min Speed
									Special Function:
								000 – 069	Null
								070 – 079	Blackout Pan/Tilt Move Enable
								080 –089	Blackout Pan/Tilt Move Disable
								090– 099	Reset All
								100– 109	Zoom Reset
								110 – 119	Pan/Tilt Reset
13	14	17	18	29	30	45	46	120 – 255	Null

ERROR CODES

Error Codes subject to change without notice	
ERROR CODE	DESCRIPTION
CPU-B Error	CPU-B Error
CPU-C Error	CPU-C Error
Pan Reset Error	Pan: Reset Error
Pan Encoder Error	Pan: Reset Error
Tilt Reset Error	Tilt: Reset Error
Tilt Endcoder Error	Tilt: Encoder Error
LED Fan start errors	LED Fan Cannot Start
LED Fan stop errors	Tilt : Encoder Error
LED Fan fast speed	Led Fan Cannot Start
LED Fan slow speed	Led Fan Cannot Stop
Base Fan start errors	Led Fan Too Fast
Base Fan stop errors	Base Fan Can't Start
Base Fan speed too slow	Base Fan speed Too slow
Base Fan speed too fast	Base Fan speed Too fast

SPECIFICATIONS

Optical:

- 19x Osram 20W RGBW (4-IN-1) LEDs
- 20,000 Hour Average LED Life
- LUX @ 5M: 9960 lux @ 10-degrees; 694 lux @ 60-degrees

Effects:

- 3-zone or 7-zone Ring Control with Color Macros
- Variable Strobe & Pulse effects

Connections:

- Seetronic locking power In/Out to daisy chain power
- Daisy chain up to 5 fixtures @ 120V, 11 fixtures @ 230V
- 3-pin & 5-pin In/Out DMX Connections
- With Wired Digital Communications Network

Control:

- Motorized Zoom: 10 ~ 60-degrees
- Control: DMX-512 & RDM (Remote Device Management)
- 8 DMX Channel Modes: 13 / 14 / 17 / 18/ 29 / 30 / 45 / 46
- 64 built-in Color Macros
- Color display with touch buttons
- 3 or 7 zones of LED ring control
- Smooth 0-100% Dimming
- Fine 16-bit Dimming
- 6 Dimmer Curve modes
- Fine 16-bit Zoom control
- Built-in USB software upgrade port
- Various Strobe speeds (1-40Hz)
- Pan: 540-degree (plus fine 16-bit pan)
- Tilt: 270-degrees (plus fine 16-bit tilt)

Electrical:

- Multi-voltage operation: 100-240V, 50-60Hz
- Power Consumption: 285W Max

Dimensions / Weight:

- Dimensions (LxWxH): 12.1"x7.7"x15.5" / 306.6x195x393.3mm
- Weight: 20 lbs. / 9.4kg.

What's In The Box:

- Two Omega Brackets
- Twist lock power cable

Ratings / Approval:

- cETLus Approved (Control #4000358)



Specifications and documentation subject to change without notice.

DIMENSIONS

*DRAWINGS NOT TO SCALE. DIMENSIONS FOR INFORMATION ONLY AND SUBJECT TO CHANGE WITHOUT NOTICE.

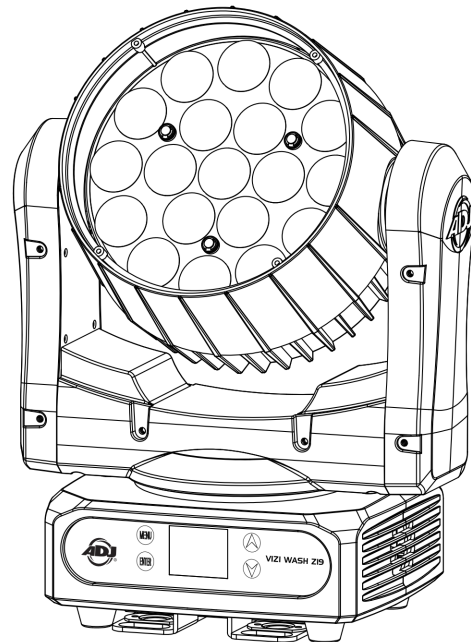
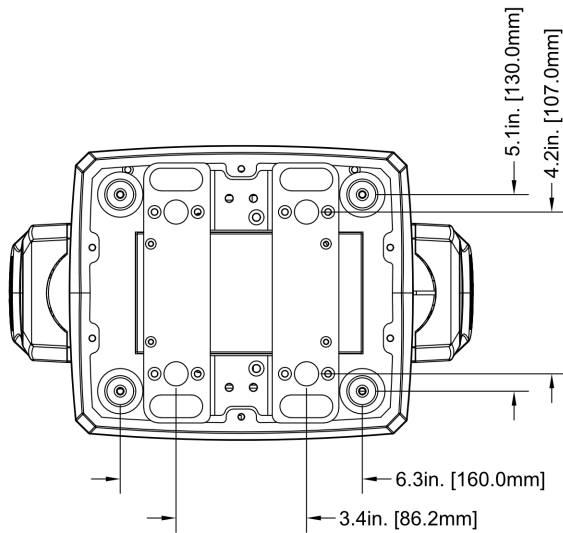
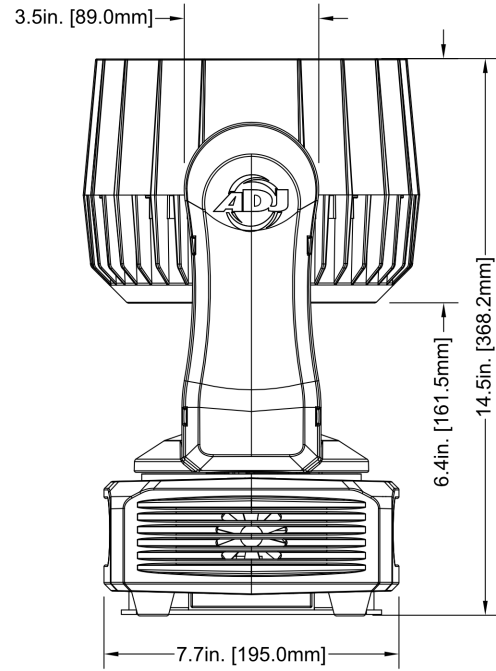
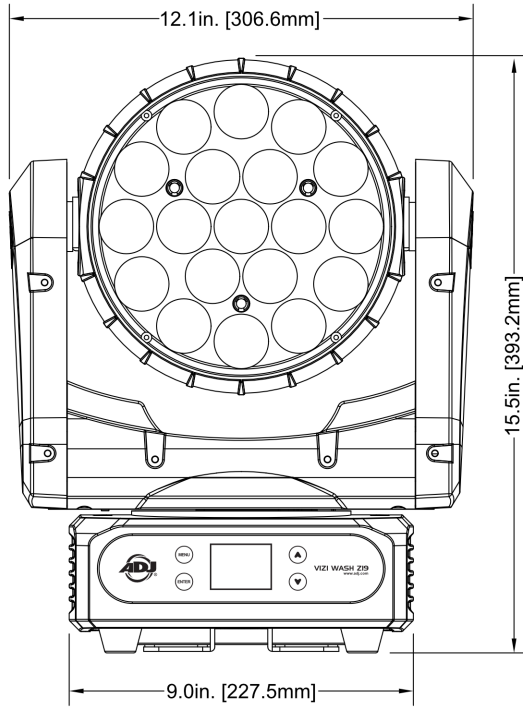

FCC STATEMENT

This device complies with Part 15 of the FCC Rules. Operation is subject to the following two conditions: (1) this device may not cause harmful interference, and (2) this device must accept any interference received, including interference that may cause undesired operation.

FCC RADIO FREQUENCY INTERFERENCE WARNINGS & INSTRUCTIONS

This product has been tested and found to comply with the limits as per Part 15 of the FCC Rules. These limits are designed to provide reasonable protection against harmful interference in a residential installation. This device uses and can radiate radio frequency energy and, if not installed and used in accordance with the included instructions, may cause harmful interference to radio communications. However, there is no guarantee that interference will not occur in a particular installation. If this device does cause harmful interference to radio or television reception, which can be determined by turning the device off and on, the user is encouraged to try to correct the interference by one or more of the following methods:

- Reorient or relocate the device.
- Increase the separation between the device and the receiver.
- Connect the device to an electrical outlet on a circuit different from which the radio receiver is connected.
- Consult the dealer or an experienced radio/TV technician for help.

Energy Saving Matters (EuP 2009/125/EC)

Saving electric energy is a key to help protecting the environment. Please turn off all electrical products when they are not in use. To avoid power consumption in idle mode, disconnect all electrical equipment from power when not in use. Thank you!



